



Camshelving®
GN 2/1 Food Pan Trolley

Project _____

Item No. _____

Model No. _____

Quantity _____



Full Size Rack

Holds 36 each GN 1/1 Food Pans, 2 1/2" (6,5 cm) Deep

Half Size Rack

Holds 18 each GN 1/1 Food Pans, 2 1/2" (6,5 cm) Deep

Features & Benefits

- Multi-purpose, side load trolley for holding, storing and transporting bulk food in GN food pans. Compact design maximizes work and storage space.
- Made from an extremely strong, revolutionary composite material with a smooth, easy to clean surface.
- Lifetime warranty against rust and corrosion.
- No metal parts, welds, screws, cross bars or metal casters than can break, bend, dent, rust or corrode.
- Moves easily between kitchen, freezer, cooler and/or off premise.
- Rails accept/hold hot pans from 390°F (200°C) oven.
- No marking or metal wipe from metal pans.
- Wide 3" (7,6 cm) rail spacing offers greatest versatility and ease of use.
- Molded in lip load rails (food pan flange hangs from rails) hold 2 each food pans per rail set.
- Molded in 0.012" (3 mm) pan stops on each rail end help keep pans on the rails when turning or transporting.
- Food pan holding capacity:

	2½" (6,5 cm)	4" (10 cm)	6" (15 cm)	8" (20 cm)
Full Size Trolley				
1/1 Pans	36 each	18 each	18 each	12 each
Half Size Trolley				
1/1 Pans	18	8	8	6

- Weight bearing per rail set is 100 lbs. (45 kg). Full size unit weight bearing is 750 lbs. (340 kg). Half size unit weight bearing is 375 lbs. (170 kg).
- Four each heavy duty, 5" (12,7 cm) premium plastic swivel casters all with total locking brake. Locks swivel and wheel. Non-marking thermoplastic rubber wheel. Rust and corrosion free.
- Easy to clean. Wipe down or pressure wash.
- Ships knockdown with casters and bottom frame wedges factory installed. Minimal assembly required.
- Components are easy to remove and replace if damaged, ensuring a lifetime of service.
- Optional Heavy Duty Vinyl Cover fits full size trolley only and can be used to cover hot pans removed from 350°F (177°C) oven.
- Available in 1 color only – Speckled Gray (480).



UGNPR21F36
Full Size Trolley



UGNPR21H18
Half Size Trolley

Approvals



COMPONENT

Patent Pending.



Information and specifications are subject to change without notice. Please confirm at time of order.
© Cambro Manufacturing Company 5801 Skylab Road, Huntington Beach, California 92647-2056-U.S.A.
Telephone 714 848 1555 **Toll Free** 800 854 7631 **Customer Service** 800 833 3003
Printed in USA. 11/20

Camshelving® GN 2/1 Food Pan Trolley

Project _____

Item No. _____

Model No. _____

Quantity _____

Full Size Rack

Holds 36 each GN 1/1 Food Pans, 2 1/2" (6,5 cm) Deep

Half Size Rack

Holds 18 each GN 1/1 Food Pans, 2 1/2" (6,5 cm) Deep

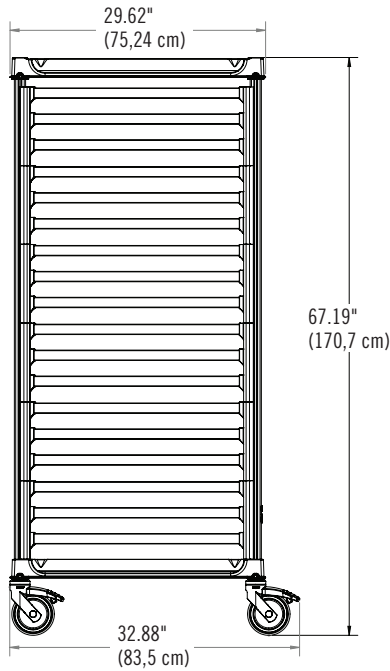

FRONT VIEW

UGNPR21F36

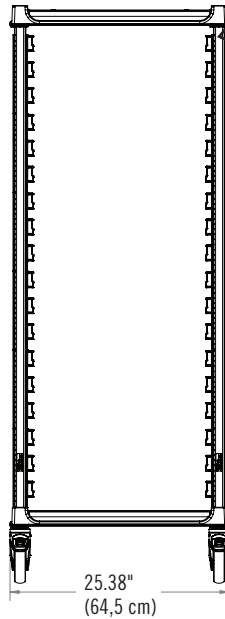

SIDE VIEW

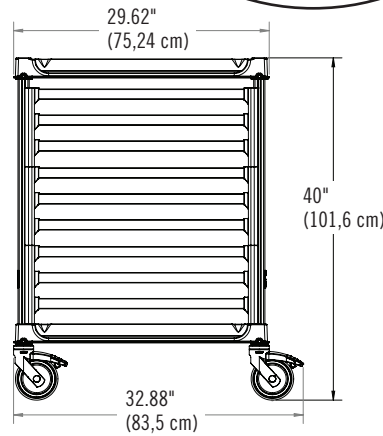

FRONT VIEW

UGNPR21H18

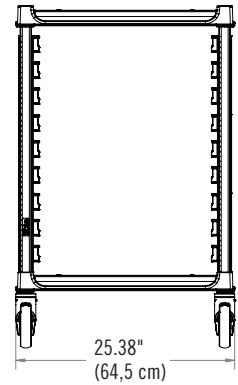

SIDE VIEW

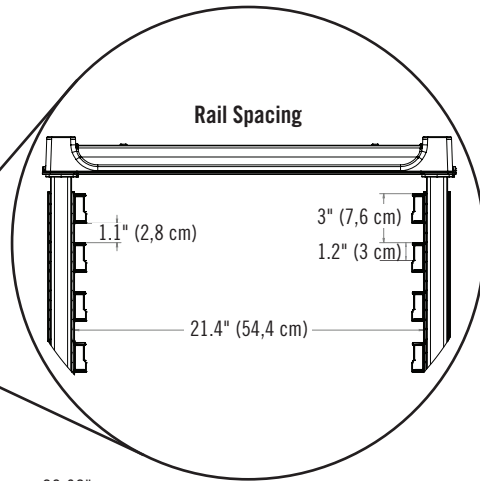

Specifications

Dimension Tolerance: +/- 1/4" (0,64 cm)

Code	Description	Load Capacity	Dimensions L x W x H*	Unit Weight
UGNPR21F36	Full Size Trolley	750 lbs. (340 kg)	32.88" x 25.38" x 67.19" (83,5 x 64,5 x 170,7 cm)	60.9 lbs. (27,68 kg)
UGNPR21H18	Half Size Trolley	375 lbs. (170 kg)	32.88" x 25.38" x 40" (83,5 x 64,5 x 101,6 cm)	37.7 lbs. (17,14 kg)

* Includes 5" (12,7 cm) Casters.

Optional Accessories

Full Size Vinyl Cover GBCTUGNPR21

Standard Colors

Speckled Gray (480)

Architect Specs

Mobile Posts: Proprietary non-corrosive composite material. Post Connector Frames: Reinforced nylon. Side Rail Panels: Proprietary non-corrosive composite material and reinforced polypropylene. Post Connector Frame Wedges: Reinforced polypropylene. Casters: 5" (12,7 cm), plastic nylon frame, metal stem, non-marking thermoplastic wheel, with total locking brake. Units ship knockdown with casters and bottom post connector frame wedges factory assembled onto posts. Holds GN 1/1 size pans only. Weight bearing per rail set is 100 lbs. (45 kg). Full size unit weight bearing is 750 lbs. (340 kg). Half size unit weight bearing is 375 lbs. (170 kg). Lifetime warranty against rust and corrosion. Unit color is Speckled Gray (480).

Approvals



COMPONENT

Patent Pending.

CAMBRO
TRUSTED FOR GENERATIONS™
www.cambro.com

Information and specifications are subject to change without notice. Please confirm at time of order.
© Cambro Manufacturing Company 5801 Skylab Road, Huntington Beach, California 92647-2056-U.S.A.
Telephone 714 848 1555 Toll Free 800 854 7631 Customer Service 800 833 3003
Printed in USA. 11/20

CSUGNPR2DOM

0062012